

## **A solar-powered telemetry system on base of a repeater**

Ioannis N. Vandikas, SV2CPH  
Technological Education Institute (T.E.I.) of Western Macedonia  
Koila Kozani, 50100, Greece  
[efarmogigr@hotmail.com](mailto:efarmogigr@hotmail.com)

### **Abstract**

This paper presents an approach for collecting and transmitting thermal and electrical properties of a repeater, powered by a solar panel. The approach is characterized by high accuracy, low cost and low power consumption. The approach incorporates 2 sensors for voltage measurement, 2 sensors for current measurement 3 sensors for temperature measurement and one auxiliary sensor. We have found that the aforementioned configuration facilitates the process of collecting accurate measurements from the repeater. The core of the system is an MCU which collects measurements by converting analog signals to digital. Then it processes them and creates digital packets in accordance with the AX.25 protocol. Data is transmitted in a rate of 1200Baud with an AFSK configuration in the VHF zone. The data can be decoded by any Narrow FM receiver with a TNC or by a computer with a sound card. The thermal sensors offer an accuracy of 1oC, while the voltage sensor an accuracy of 0.1V. Finally yet importantly the current sensor offers an accuracy of 0.18%.

**Keywords:** Telemetry, AX.25, APRS.

### **Introduction**

The development of M2M (Machine to Machine) systems is continually increased not only in the industry area but also in the area of radio amateurs. The main goal of this project is the development of a telemetry system in a solid, reliable manufacturing with low cost and low power consumption. The data transmission is based on protocol AX.25 that is widely acceptable by radio amateur's community. (TARP, 2000)

In many applications there is the need of measurement and data transmission to distance: for example to Remote Monitoring for repeater (Voice - digital) , Energy Management to Pico or Nano-satellite (Hank Heidt, & Kevin Doherty, 2000), Balloon payloads (Carl Wick, 1997), weather station (David R. Andersen, 2001). On solar powered systems we need to receive data that concern voltage, current and temperature. The use of telemetry systems makes the check easier and the research of technologies and materials. In Fig. 1 is illustrated the topology of the telemetry system on a repeater.

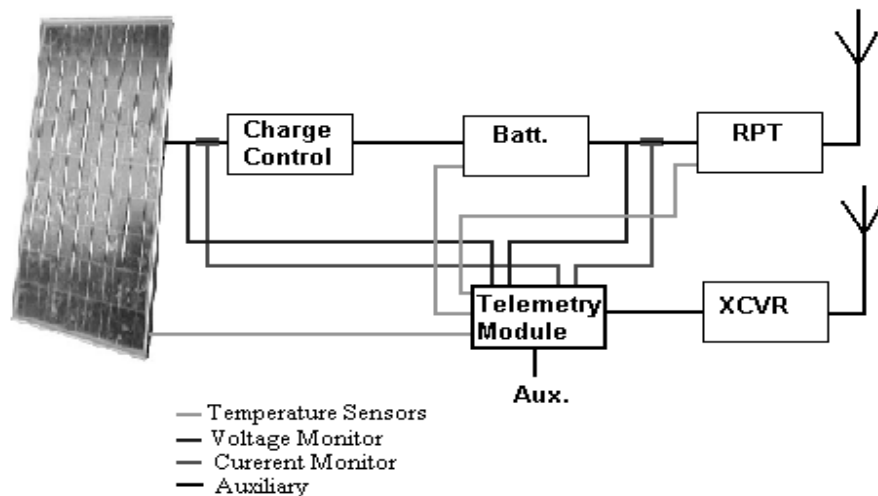

**Figure 1: Telemetry System's topology for a repeater powered by batteries solar panel.**

In Fig. 1 three points are illustrated for temperature measurement. Specifically temperature of the solar panel, temperature of the battery, temperature of the repeater. The voltage measurement is done on the output of the solar panel and on the terminals of the battery (specific for 12V). The current measurement is done based on the current provided by the solar element and also by a repeater's feeding point. These points have been chosen for the observation of the solar panel - the charge system – of the battery and the repeater. For a more specialized application these points can change in order to satisfy specific supervisors. All data collected create the frame that sends in the form of packages to a transceiver and also to telemeter. Then follows the receiving and decoding of data in order to process or store them.

## Implementation

The design goals for this implementation are the achievement of low energy consumption and data sampling accuracy. In order to accomplish these goals we use analog and digital technology based on integrated circuits. The core is the Microcontroller 18F452 that receives analog signals from the sensors converts them into digital and prepares packages with APRS®<sup>1</sup> prescriptions so as to be transmitted. Specifically there are three types of analog sensors in seven analog inputs of the microcontroller though the eighth analogue remains for subsidiary use. The data collection concerns voltage measurement, current and temperature measurement. Moreover the microcontroller communicates through I2C with a real time clock (real time clock, RTC) for it's continuously function is supplied by a Li-ion battery. All measurement data of time are converted into appropriate packages according the prescriptions of the AX.25 protocol with the speed of 1200Baud. On the output of MCU we place a low-pass filter to create a net acoustic signal. The packages are converted into AFSK configuration so as to be transmitted to a transceiver. For the speed of 1200Baud most transceivers can satisfy this demand without any need of modifications. The choice of AFSK has been done due to its wide spread in the radio amateur community and also to its easy creation and decoding.

For the pickup there can be used receivers or transceivers N-FM VHF, next must be done the decoding of their signals. We use TNC (Packet-Radio Controller), but also with a sound card of a PC, we can decode data. The software handles the process, the graphical illustration or the storage of data. Mass programs are presented for the decoding and the appearance of data.

<sup>1</sup> APRS® is a registered trademark of Bob Bruninga.

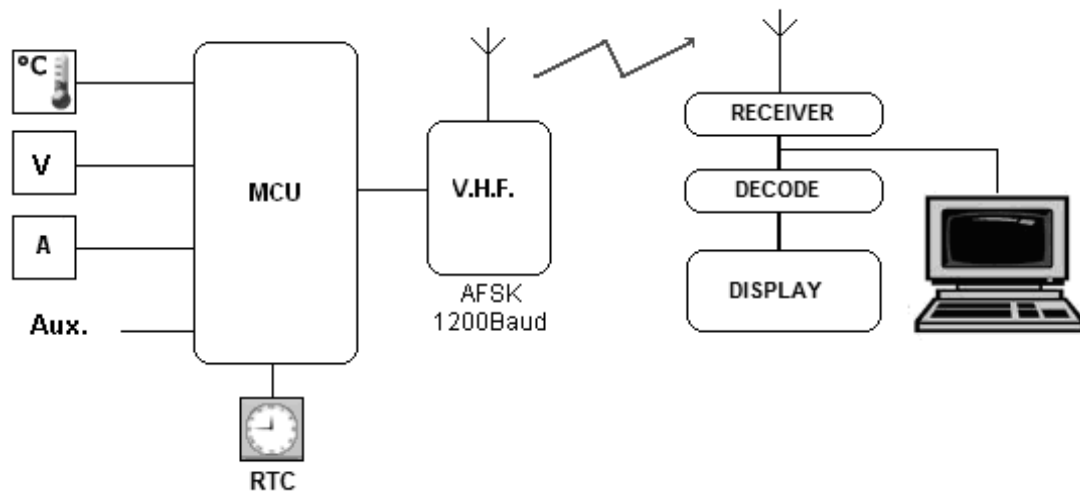

**Figure 2: Block Diagram of telemetry.**

## Sensors

The accumulation of electrical and thermal data is materialized using three types of sensors:

- Temperature
- Voltage monitor
- Current monitor

In the market there is a shower of temperature sensors that satisfy any designing demand. In this project there was used the LM335 of low cost sensor based on silicon. The LM335 directly calibrated in Kelvin  $+10\text{mV}/^\circ\text{K}$  temperature range  $-40\dots+100\text{ }^\circ\text{C}$  that supplies the environmental temperatures. Its output is guided to the converting inputs from analog to digital that has the mcu. The initial fault is to  $1\text{ }^\circ\text{C}$  any calibration demanded can be done through software.

For the voltage measurement we use voltage divider based on resistors of 1% accuracy and with an aspect ratio 5:1. Additionally we use transient voltage suppressor diode to 30V in order to protect the inputs from hypertensions. The fault remains low on the absolute maximum value 0,1V; we can achieve additional decrease by calibration through the software.

The current measurement is reduced to voltage measurement and we chose the integrated circuit MAX4372 Low-cost, precision, high-side current-sense amplifier (Fig. 3). The maxim company offers three editions with different amplification MAX4372 T/F/H that supply 20V/V, 50V/V, and 100V/V respectively. The measurement takes place on resistors  $0,01\Omega$  1% maximum current 10Amps we have voltage recession of 0,1V by using the MAX4372F we take maximum output 5V. This voltage is appropriate for the A/D input of the mcu. The accuracy of resistors is important, for the measurement as  $R_{\text{SENSE}}$  we can use a copper PC board traces to create a sense resistor.

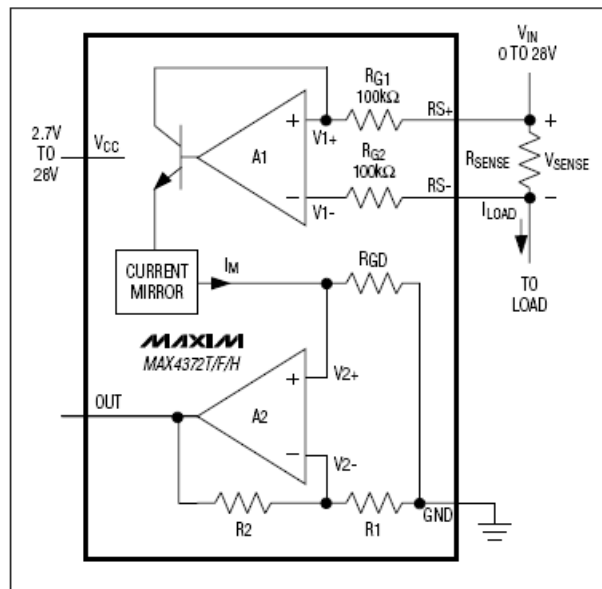

**Figure 3: Functional Diagram of MAX4372.**

## RTC

It is based on the integrated circuit DS1307 is a low power full BCD clock/calendar and communicates with the microcontroller through the I2C bus. There are also 56-Bytes, battery-backed, Nonvolatile RAM for data storage. With a Li-ion battery connected we make sure that functions continuously with current of  $0,5\mu\text{A}$  that supplies autonomy for 8-10 years.

## MCU

The microcontroller's responsibilities are to convert analog to digital signals and process them. We chose Microchip 18F452 CMOS technology with 32K Flash Memory, 100nS instruction execution, 34pins I/O. Support I2C Master / slave mode, Addressable USART module: support RS-485 and RS-232. Also 8 channels 10-bit ADC fast sampling rate with linearity  $\approx <1\text{LSB}$ . Its main advantage is reprogramming ease and low power consumption. Such a microcontroller is an essential building block for software development purposes.

## AX.25 communication protocol

The AX.25 protocol is based on HDLC format. The general frame format used for data transmission is show in Table 1 Briefly described the functionality of each field in the frame is:

FLAG: Indicates start and stop of the frame.

ADDRESS: Contains sender address, receiver address.

CONTROL: Identifies the type of frame which in this case is an information frame.

PID: Identifies the type of top-level protocol.

INFO: Contains from zero to 256 bytes of data.

FCS: The frame checks sequence.

FLAG	ADDRESS	CONTROL	PID	INFO	FCS	FLAG
(1)	(21)	(1)	(1)	(256)	(2)	(1)

**Table 1: AX.25 format.**

## Functionality

With power supply the circuit begins to work and checks the position of Jumper 1 connected directly to the mcu. If the Jumper 1 is not positioned data measurements are collected from the sensors, the time and the package for transmitting is created. For the transmitting we check through the speaker of the transceiver if the frequency is available or busy. After the check starts initially the instruction PTT and with a TX delay we send the audio packet for readout. In this case (without configuration) elements for its full development are missing such as call sign, position and time. In a different case that the jumper 1 is positioned configuration begins that includes 12 parameters as they are illustrated in table 2. This procedure is necessary not only for the telemetry data but also for the corrections on the values of measurements. For the system's errors that occur and are of steady value we can insert a corrective value to decrease them. With this calibration through software we can manage accuracy in very good levels. All parameters positioned are stored in the eeprom memory of the microcontroller. For any correction we must position again the jumper 1 and then settle down the new parameters.

The parameters inserted are the call sign, time, and data of geographical position: Longitude, Latitude we receive from GPS receiver or maps. Telemetry cannot receive direct Data out from a GPS receiver but we position it through configuration. A correction on the software could allow us the direct connection and transmitting data on a moveable system. Another parameter are the Digipeaters with which collaborates and concern the APRS network of the area. The repetition time of transmitting packages (1...99minutes), also TX Delay (low value 30ms – high value 90ms). T1, 2, 3 and Aux are correction values for the temperature (positive or negative value) and also for the assistance input. A correction influences algebraically the current value. The last parameter is Under Voltage Lock below this value packages are not transmitted and the function of ptt in the transceiver is not activated. With this instruction we can handle better the energy when the voltage gets under a certain safety value.

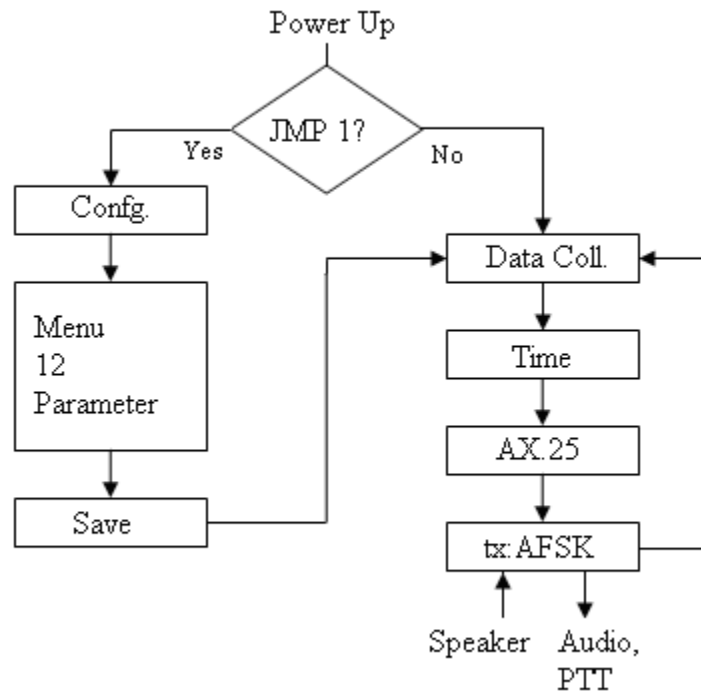

Figure 3: Flow chart.

Number	Parameter	Format	Description
1	Station callsign	xxxxxxx-x	Station name
2	Time	Yymmddhhmm	For RTC
3	Longitude	Nxx.xxxx	From G.P.S
4	Latitude	Exx.xxxx	From G.P.S
5	Digipeaters	xxxxxxx-x, xxxxxx-x	Name of Digipeaters
6	Repetition Time	xx	01...99 minutes
7	TxD	L / H	30ms/90ms
8	T1	xx.x	Temperature calibration
9	T2	xx.x	Temperature calibration
10	T3	xx.x	Temperature calibration
11	Aux	xx.x	Aux. calibration
12	Under Voltage Lock	xx.x	Tx stop under this voltage

**Table 2: Parameters Configurations.**

### Measurements and Results

In order to develop this project we took a series of measurements so as to check the good function of the circuit. The A/D converter has resolution 10-bit, 61db S/N ratio and 60db dynamic Range, absolute accuracy is 0,097%. For the voltage measurements the errors are detected on the divider of voltage and are confined with the use of accuracy resistors. During the measurements the terminal linearity is 2,02 % that corresponds to the absolute maximum error 0,101V. The error refers concertedly not only to the resistors of the divisor but also to the A/D conversion.

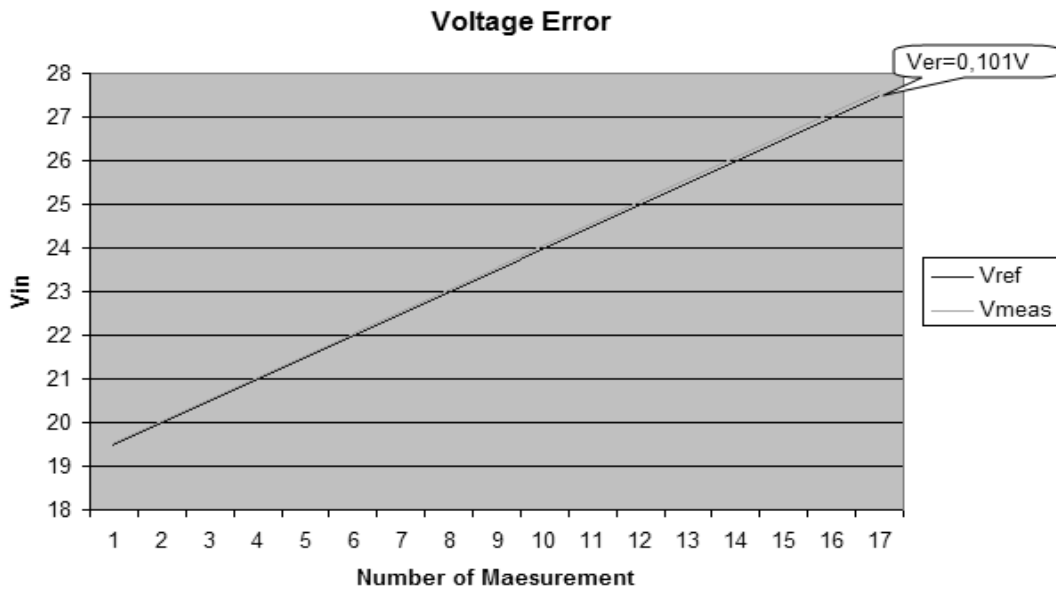
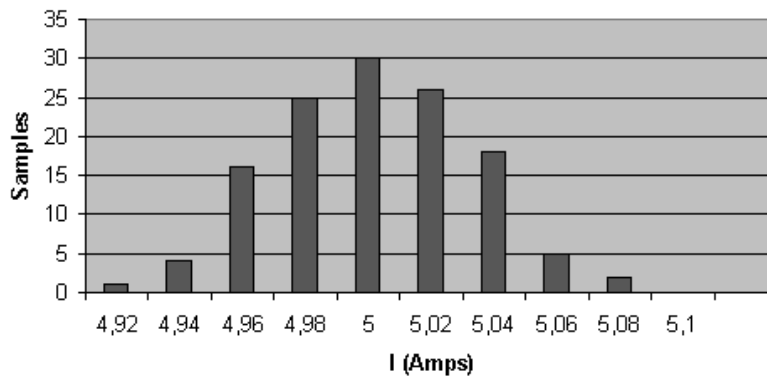

**Figure 4: Voltage error.**

To the current measurement error is inserted by the  $R_{SENSE}$ , with the integrated circuit MAX4372F and the converter A/D of the microcontroller. MAX4372F has 0,18% Full Scale Accuracy. In this measurement we focused on the repeatability and under different temperatures from 17 °C to 40°C that

influence the measurement. Repeatability concerns us because in the real environment under the impact of temperature and moisture the error of current measurement increases.

**Repeatability of current measurement**



**Figure 5: Current measurements.**

For the temperature measurement and for the values we encounter usually in the environment the error is extremely low. Only for the extreme values of temperature for example  $-40^{\circ}\text{C}$  or  $+100^{\circ}\text{C}$  the error is  $1^{\circ}\text{C}$ . The graphical representation Fig. 6 affirms the above observation and concerns the behavior of the sensor (it does not include the error of the A/D). We can incorporate to the software a sub-program for the automatic correction of the error on the extreme values of the temperature but it is not a crucial parameter.

**Temperature Error**

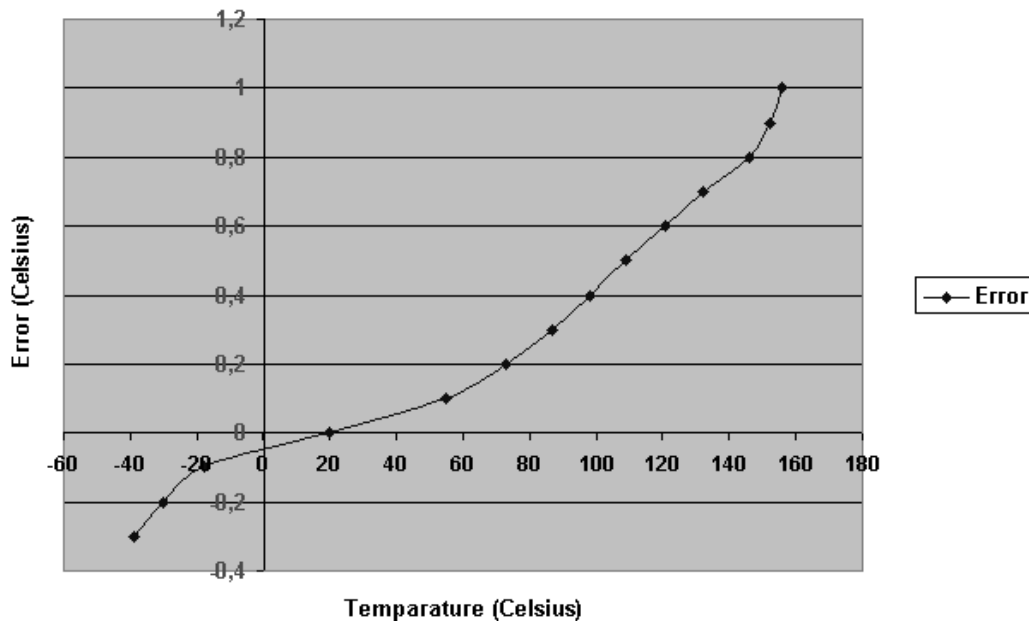

**Figure 6: Temperature error.**

## **Energy consumption**

With DC power supply 12V current is 20mA without indicator Leds. This allows power supply from a battery with photo-voltaic cells. Moreover with the function "Under Voltage Lock" the transmission of telemetry packages is interrupted from the transceiver for the better energy administration.

## **Conclusion**

This project presents the capability of data collection via sensors, process and transmission of this data. By using analog and digital techniques we can achieve a reliable, low cost unity of telemetry. The use of a mcu assists the development of autonomic telemetry units, solid, with small size and flexibility through software. With accuracy in the temperature measurement 1 °C, in the voltage measurement 0,1V, and 0,18% for current measurement we cover sufficiently the supervision needs of a repeater. In such case we achieve observation on devices or parts under different electrical and climatic circumstances and also through time with high accuracy. We can add to the system in the assistance input a pyranometer (Solar Radiation Sensor) for a full study of solar and technological solar panels.

## **Reference**

TAPR, (2000) AX.25 Link Access Protocol for Amateur Packet Radio TAPR version 2.2 chapter 13 p. 68-70

Carl Wick, N3MIM, (1997) APRS Telemetry System Micro Interface Module (MIM)

David R. Andersen, K0RX (2001), uWeather<sup>TM</sup> - An APRS-compatible weather station TAPR and ARRL 20th Digital Communications Conference

Hank Heidt, N4AFL & Kevin Doherty, (2000) StenSat Journal (Our Experience Building a Picosatellite)